Operation Instruction



EBH5201

***HDcctv 1080p
Indoor Compact Bullet Camera***

EBH5201

EVERFOCUS ELECTRONICS CORPORATION

Operation Instruction

© 2013 EverFocus Electronics Corp

Please read this manual first for correct installation and operation. This manual should be retained for future reference. The information in this manual was current when published. The manufacturer reserves the right to revise and improve its products. All specifications are therefore subject to change without notice.

All rights reserved. No part of the contents of this manual may be reproduced or transmitted in any form or by any means without written permission of the EverFocus Electronics Corporation.

PRECAUTIONS

1. **Do not install the camera near electric or magnetic fields.**
Install the camera away from TV/radio transmitters, magnets, electric motors, transformers and audio speakers since the electromagnetic fields generated from these devices may distort the video image or otherwise interfere with camera operation.
2. **Never disassemble the camera beyond the recommendations in this manual nor introduce materials other than those recommended herein.** Improper disassembly or introduction of corrosive materials may result in equipment failure or other damage.
3. **Try to avoid facing the camera toward the sun.** In some circumstances, direct sunlight may cause permanent damage to the sensor and/or internal circuits, as well as creating unbalanced illumination beyond the capability of the camera to compensate.
4. **Keep the power cord away from water and other liquids and never touch the power cord with wet hands.** Touching a wet power cord with your hands or touching the power cord with wet hands may result in electric shock.
5. **Never install the camera in areas exposed to oil, gas or solvents.**
Oil, gas or solvents may result in equipment failure, electric shock or, in extreme cases, fire.
6. **Cleaning**
For cameras with interchangeable lenses, do not touch the surface of the sensor directly with the hands. Use lens tissue or a cotton tipped applicator and ethanol to clean the sensor and the camera lens. Use a damp soft cloth to remove any dirt from the camera body. Please do not use complex solvents, corrosive or abrasive agents for cleaning of any part of the camera.
7. **Do not operate the camera beyond the specified temperature, humidity or power source ratings.**
This camera is suitable for indoor operation. Use the camera at temperatures within -10°C~50°C (14°F~122°F) and in an indoor environment; this device is not rated as weather proof. The input power source is 12VDC. The use of properly fused or Class 2 power limited type supplies are highly recommended.
8. **Mounting**
Use care in selecting a solid mounting surface which will support the weight of the camera plus any wind, snow, ice or other loading, and securely attach the camera to the mounting surface using screws and anchors which will properly support the camera. If necessary (e.g. when mounting to drop ceilings) use a safety wire to provide additional support for the camera.



ATTENTION! This is a class A product which may cause radio interference in a domestic environment; in this case, the user may be urged to take adequate measures.



Federal Communication Commission Interference Statement

This equipment has been tested and found to comply with the limits for a Class B digital device, pursuant to Part 15 of the FCC Rules. These limits are designed to provide reasonable protection against harmful interference in a residential installation. This equipment generates, uses and can radiate radio frequency energy and, if not installed and used in accordance with the instructions, may cause harmful interference to radio communications. However, there is no guarantee that interference will not occur in a particular installation. If this equipment does cause harmful interference to radio or television reception, which can be determined by turning the equipment off and on, the user is encouraged to try to correct the interference by one of the following measures :

- Reorient or relocate the receiving antenna.
- Increase the separation between the equipment and receiver.
- Connect the equipment into an outlet on a circuit different from that to which the receiver is connected.
- Consult the dealer or an experienced radio/TV technician for help.

FCC Caution: Any changes or modifications not expressly approved by the party responsible for compliance could void the users' authority to operate this equipment.

Table of Contents

1. PRODUCT OVERVIEW	7
1.1 FEATURES	7
1.2 ACCESSORY PARTS LIST	8
1.3 SPECIFICATIONS	9
1.4 DIMENSIONS	10
2. CAMERA COMPONENT DESCRIPTION	11
3. INSTALLATION	12
4. OSD Structure.....	14

1. Product Overview

The EBH5201 is an HDcctv indoor bullet camera with Digital Day/Night capability in a compact housing only 1.77" in diameter and less than 4" long. Based on a 1/3" Panasonic 2.1 megapixel progressive scan sensor and wide angle 2.45mm megapixel lens for HD 1080p resolution 100% digital images, it delivers vastly superior video quality compared to traditional CCTV images. This superior resolution not only captures more critical evidentiary information, but the inherent ability for megapixel video also extends the area of coverage, expedites completion of investigations, resolves complaints and reduces both capital and operational costs. Designed with 4X Digital Slow Shutter low light enhancement technology, the EBH5201 can captures color images in low light without ghosting, or it can switch to monochrome mode automatically in low light environments.

This highly advanced imaging system also incorporates state of the art optical enhancement technologies: Lens Shading Correction compensates to eliminate artificial shadows caused by attenuation of light as it traverses the outer portions of the lens; Digital Slow Shutter low light enhancement for optimal low light sensitivity combines with Digital Noise Reduction (DNR) to maximize image clarity while conserving DVR disk storage space; digital zoom with electronic PTZ to fine tune field of view; Highlight Suppression (HSBLC) to handle imbalance due to bright spots in the scene; image flip/rotate, and much more.



No major upgrade to the IT network is required to deploy this powerful technology; HDcctv cameras communicate at digital speeds up to 1.5Gb/s over existing or new coaxial cable (RG59 or other types for longer distances), using industry standard BNC connectors. With its NTSC/analog secondary output to allow convenient aim and focus using a standard hand held test monitor, full OSD controls, and 94° wide horizontal viewing angle megapixel lens the EBH5201 delivers flexible, robust coverage in a wide range of low light surveillance applications while delivering stunning HD image quality

1.1 Features

- HDcctv 2.1 Megapixel real time 1920x1080/1280x720 HD video over coax for superlative image detail
- Supports video outputs of 1080p30/25 and 720p60/50 (Field Select)
- Choice of Day/Night operation or Full Color Images in Low Light
- Provides DNR to improve picture clarity while enabling DVRs to improve disk storage utilization
- Flexible mounting and positioning - mount included, or fits any 1/4"-20 mount
- SD TV out for aim and focus using standard hand held test monitor
- 2.45mm megapixel lens captures a 94° wide horizontal field of view
- Easy to use OSD setup menu with an array of options
- Enhanced low light sensitivity through a sensitivity increase setting of up to 4x
- Lens Shading Compensation offsets diminished light transmission through lens periphery for uniform image illumination
- HSBLC [Highlight Suppression Back Light Compensation] to suppress imbalance due to bright areas in the scene
- Digital zoom increases effective lens magnification up to 20x
- Up to 30 Privacy Zones
- Dead pixel compensation for increased clarity and extended service life

1.2 Accessory Parts List

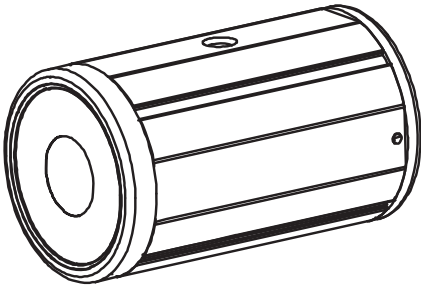
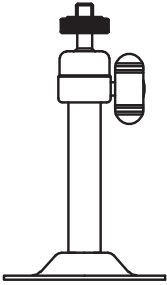
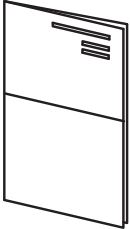
 Please be careful when you unpack the box due to the electronics devices inside. Check and make sure that you have all the items listed below inside the original box:

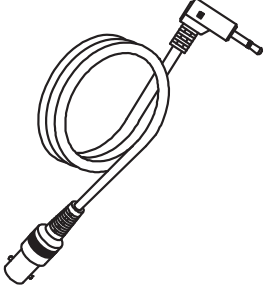
Camera	Mounting Bracket	
		
Manual	Screws	Service Video Cable
		

Please Note: If an item appears to have been damaged in shipment, replace it properly in its carton and notify the shipper. If any items are missing, notify your EverFocus Electronics Corp. Sales Representative or Customer Service. The shipping carton is the safest container in which the unit may be transported. Save it for possible future use.

1.3 Specifications

Pickup Device	1/3" Panasonic 2.1 Megapixel Color Progressive CMOS sensor
Image Pixels	1920(H)x1080(V) with 2.75 μ x 2.75 μ pixel size
HDcctv Image Area Dimensions	5.28mm (H) x 2.97 mm(W); \varnothing 6.06 mm area diagonal
Sensitivity	0.1 lux/F1.2 (DSS OFF)
S/N Ratio	More than 50dB
Video Format Main Output	HDcctv
Video Resolution/Mode Main Output	Field Select 1080p30/25, 720p60/50
Main Output Connector	BNC-F
Video Format Test Output	NTSC/PAL Selectable
Test Output Connector	Pin connector on board; adapter to BNC supplied
Lens Type	2.45mm Fixed Focal Length
FOV Angle	94°Horizontal
Shutter Speed	Auto / Manual Selectable
OSD	Yes (5-axis joystick control)
D/N Mode	Auto, Color, B/W (Electronic D/N)
Exposure Control	Automatic Electronic Shutter
DSS	Low light boost 2X, 3X, 4X
Lens Shading Compensation	On / Off
Auto Gain Control	Variable 0~23dB (23bD=200x)
White Balance	ATW/Push/Manual/Outdoor/Indoor
DNR	Low / Medium / High
HSBLC	On / Off
Digital Zoom	1X ~20X
Power Source & Consumption	DC12V (+/-10%) @ 160mA
Image Flip	Off/V Flip/H Flip/H+V Flip (Rotate)
Programable Privacy Zones	30 areas independently adjustable for size, location, color
Weight	136.1g/408oz (Camera Only; Mount adds 113.4g/4oz)
Dimensions	Body: 86.7mm/3.41"(L) x \varnothing 44mm/ \varnothing 1.77" Diameter(W) Mount: \varnothing 60mm/ \varnothing 2.36" Diameter(W) [Adds 97.6mm/3.84" max to height]
Operating Temperature	-10°C~50°C ; 14°F~122°F
Operating Humidity	20%~80% humidity, non-condensing
Certifications	FCC/CE

1.4 Dimensions

Inches:

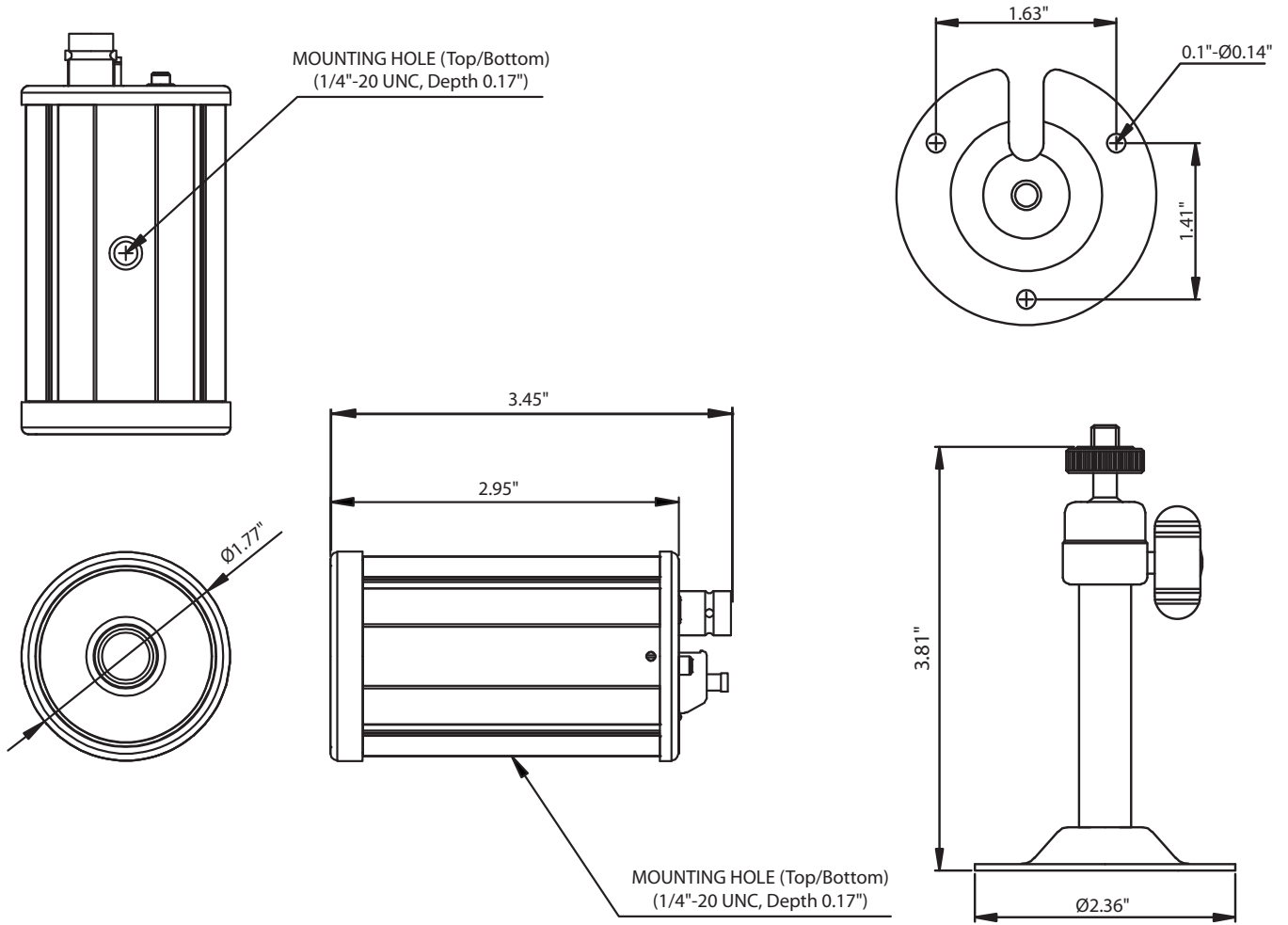

2. Camera Component Description

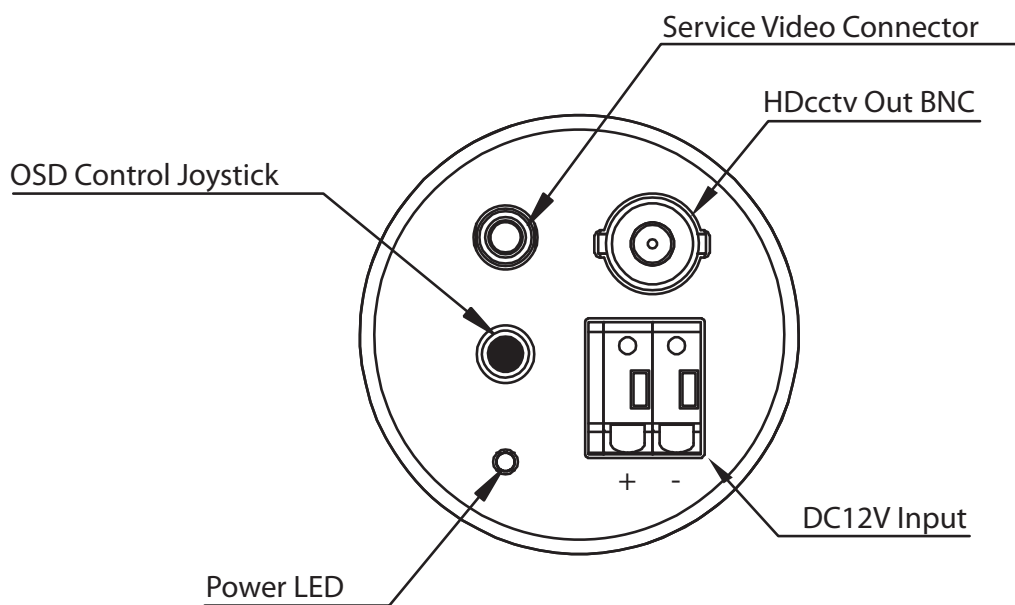

3. Installation

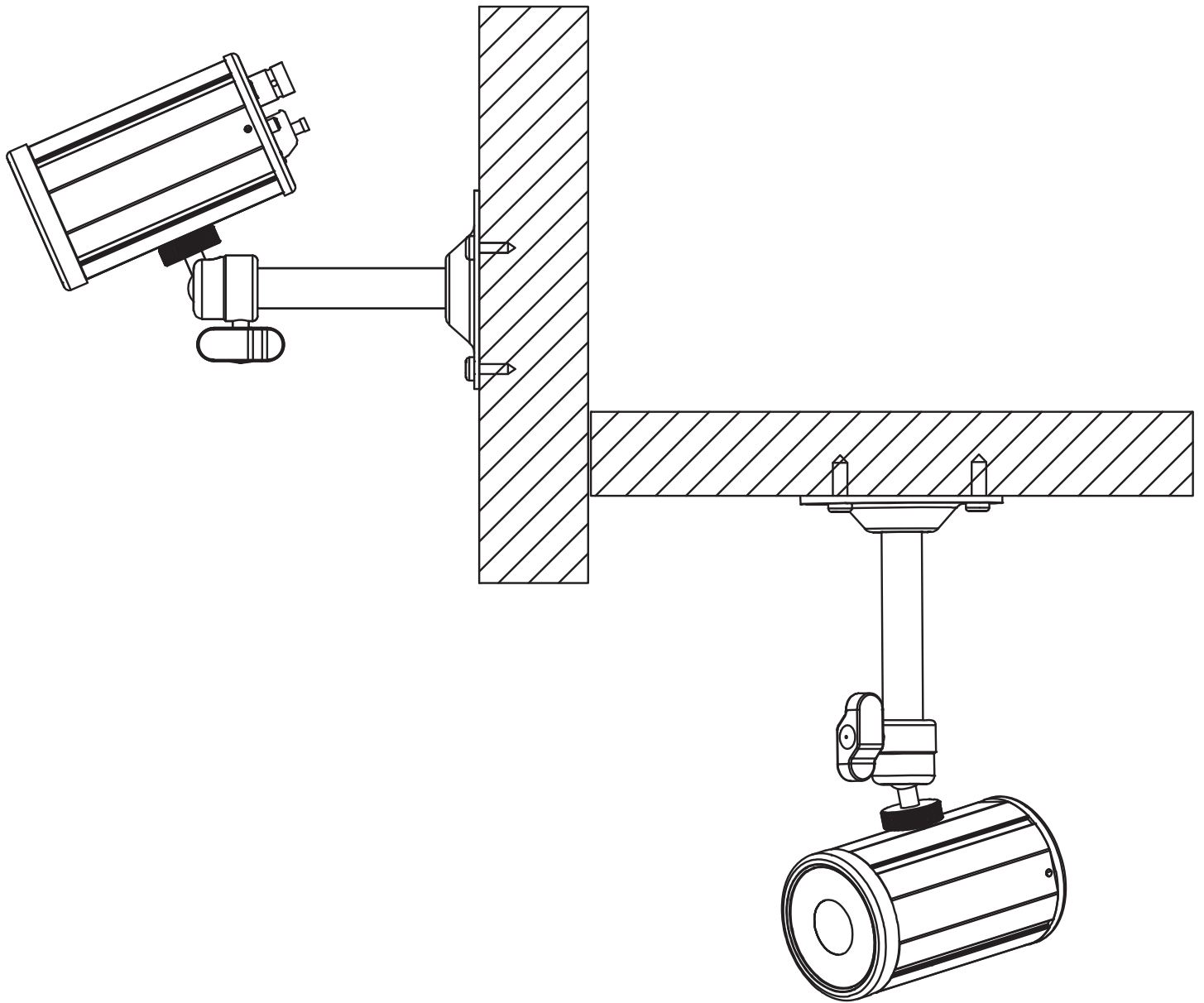

Connections

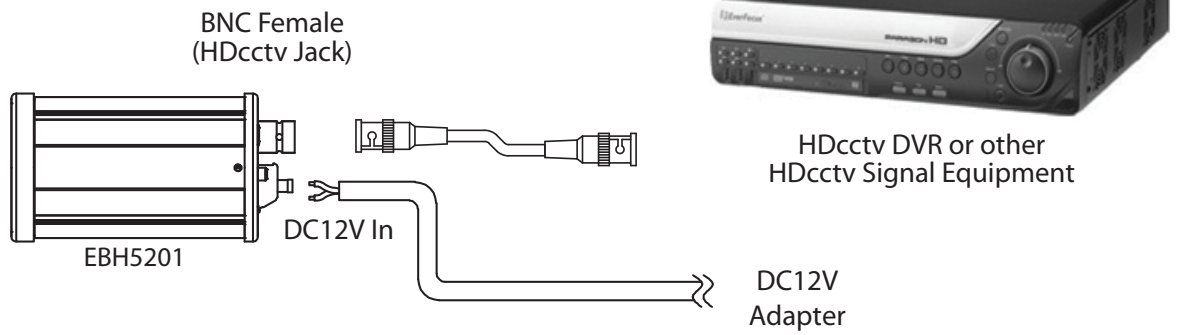

*Service Video Connector

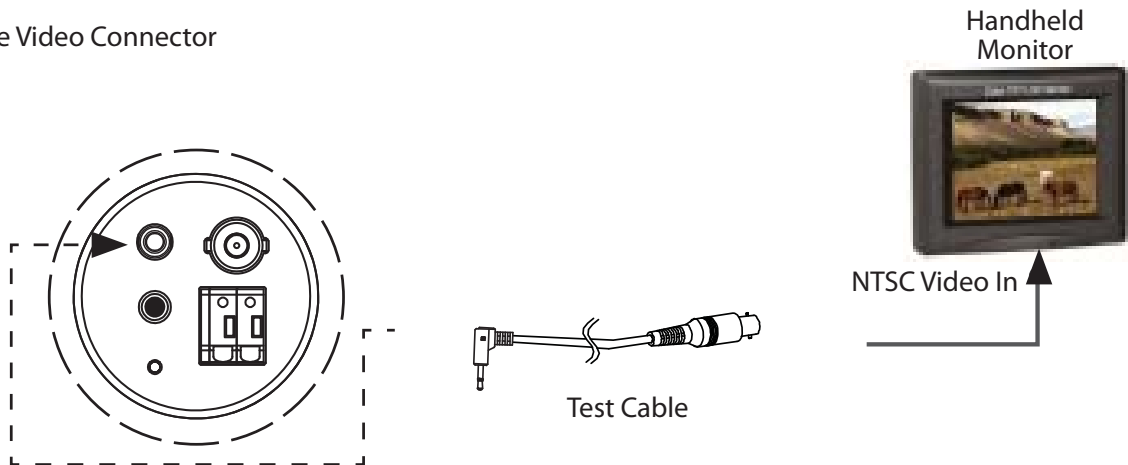

* NOTE



When installing the camera, make sure that all cable ends and connectors are protected from humidity and other outdoor environments.

4. OSD Structure

Chapter

4

Main	Sub Menu	Sub Menu		
SETUP				
EXPOSURE	BRIGHTNESS	0 ~ 20		
	SHUTTER MODE	AUTO, MANUAL		
	SHUTTER	1/30(25), 1/60(50), 1/120(100), 1/250, 1/700, 1/1K,		
	SPEED	1/1.6K, 1/2.5K, 1/5K, 1/7K, 1/10K, 1/30K.		
	DSS (Digital Slow Shutter)	OFF, X2, X3, X4.		
	AGC MAX	0 ~ 23dB		
	INITIAL			
	RETURN			
WHITE BALANCE	WB MODE	AUTO / PUSH LOCK / MANUAL		
	CHROMA	0 ~ 20		
	KELVIN	LOW, MIDDLE, HIGH		
	RED GAIN	0 ~ 20		
	BLUE GAIN	0 ~ 20		
	PUSH AUTO	-		
	INITIAL			
	RETURN			
BLC	MODE	OFF, BLC		
	BLC OSD	OFF, ON		
	BLC X - POSITION	0 ~ 20		
	BLC Y - POSITION	0 ~ 20		
	BLC X - SIZE	0 ~ 20		
	BLC Y - SIZE	0 ~ 20		
	INITIAL			
	RETURN			
DAY & NIGHT	D&N MODE	AUTO, COLOR, BW		
	DWELL TIME	1sec ~ 10sec		
	AGC THRS	0 ~ 20		
	MARGIN	0 ~ 20		
	INITIAL			
	RETURN			
IMAGE	SHARPNESS	0 ~ 10		
	MIRROR	OFF, ON		
	FLIP	OFF, ON		
	DZOOM(Digital Zoom)	1X ~ 20X		
	SHADING (LSC)	OFF, ON		
	HLMASK (HSBLC)	OFF, ON	HLMASK LEVEL	0 ~ 20
			HLMASK COLOR	WHITE, YELLOW, CYAN, GREEN MAGENTA, RED, BLUE, BLACK
INITIAL				
RETURN				
Image	DNR	OFF, LOW, MIDDLE, HIGH		
	INITIAL			
	RETURN			

4. OSD Structure

Main	Sub Menu	Sub Menu	
SPECIAL	CAM TITLE	CAM TITLE	
		0 1 2 3 4 5 6 7 8 9 A B C D E F G H I J K	
		L M N O P Q R S T U V W X Y Z ! - () < >	
		SPA >> << BAK	
		LOCATION	
		RETURN	
	LANGUAGE	ENGLISH, RUSSIAN, SPANISH, GERMAN, FRENCH, PORTUGUESE	
	PRIVACY	OFF, ON	ZONE NO 0 ~ 29
			MASK MODE OFF, ON
			X - POSITION 0 ~ 60
			Y - POSITION 0 ~ 40
			X - SIZE 0 ~ 40
			Y - SIZE 0 ~ 40
			COLOR BLACK, WHITE, YELLOW, CYAN, GREEN, MAGENTA, RED, BLUE
			TRANSPARENCY 100%,75%,50%,25%,0%
			INITIAL
			RETURN
	MOTION DETECT	OFF, ON	RESOLUTION 0 ~ 4
			SENSITIVITY 0 ~ 20
			WINDOW USE ON, OFF
			WINDOW TONE 1 ~ 6
			X-POSITION 0 ~ 60
			Y-POSITION 0 ~ 40
			X-SIZE 0 ~ 60
			Y-SIZE 0 ~ 40
			INITIAL
			RETURN
	DISPLAY	CAM TITLE	OFF, ON
		MOTION DETECT	OFF, ON
		ZOOM	OFF, ON
		INITIAL	
	SYSTEM	RETURN	
SHADING DET		OFF, ON	
DEFECT DET		OFF, ON	
DOUT FORMAT		720P, 1080P	
DOUT FPS		50, 60 / 25, 30	
COLOR BAR		OFF, ON	
INITIAL			
RETURN			
FACTORY DEFAULT			
EXIT			

EverFocus Electronics Corp.

EverFocus Taiwan:
12F, No.79, Sec. 1, Shin-Tai Wu Road,
Hsi-Chih, Taipei, Taiwan
TEL: +886 2 2698 2334
FAX: +886 2 2698 2380
www.everfocus.com.tw
marketing@everfocus.com.tw

EverFocus Europe - Germany:
Albert-Einstein-Strasse 1, D-46446
Emmerich, Germany
TEL: +49 2822 93940
FAX: +49 2822 939495
www.everfocus.de
info@everfocus.de

EverFocus China - Beijing:
Room 609, Technology Trade Building,
Shangdi Information Industry Base,
Haidian District, Beijing 100085, China
TEL: +86 10 6297 3336~39
FAX: +86 10 6297 1423
www.everfocus.com.cn
marketing@everfocus.com.cn

EverFocus China - Shenzhen:
4F, No. 2, D4 Building, Wan Yelong
Industrial Park, Tangtou Road, Shiyan,
Baoan, Shenzhen, Guangdong 518101, China
TEL: +86 755 2765 1313
FAX: +86 755 2765 0337
www.everfocus.com.cn
marketing@everfocus.com.cn

EverFocus USA - California:
1801 Highland Avenue, Unit A, Duarte, CA 91010, USA
TEL: +1 626 844 8888
FAX: +1 626 844 8838
www.everfocus.com
sales@everfocus.com

EverFocus USA - New York:
415 Oser Avenue, Unit S, Hauppauge, NY 11788, USA
TEL: +1 631 436 5070
FAX: +1 631 436 5027
www.everfocus.com
sales@everfocus.com

EverFocus Japan:
5F, Kinshicho City Building, 2-13-4 Koto-Bashi, Sumida-Ku,
Tokyo, 130-0022, Japan
TEL: +81 3 5625 8188
FAX: +81 3 5625 8189
www.everfocus.co.jp
info@everfocus.co.jp

EverFocus Europe - UK:
Unit 12, Spitfire Business Park,
Hawker Road, Croydon Surrey, CR0 4WD, UK
TEL: +44 (0) 20 8649 9757 / 0845 430 9999
FAX: +44 (0) 20 8649 9907
www.everfocus.com
salesuk@everfocus.com

EverFocus India:
Suite 803, Housefin Bhavan, C-21,
Bandra Kurla Complex, Bandra (East),
Mumbai 400051, India
TEL: +91 22 6128 8700
FAX: +91 22 6128 8705
www.everfocus.in
sales@everfocus.in



Your EverFocus product is designed and manufactured with high quality materials and components which can be recycled and reused. This symbol means that electrical and electronic equipment, at their end-of-life, should be disposed of separately from your household waste. Please, dispose of this equipment at your local community waste collection/recycling centre. In the European Union there are separate collection systems for used electrical and electronic product. Please, help us to conserve the environment we live in!

Ihr EverFocus Produkt wurde entwickelt und hergestellt mit qualitativ hochwertigen Materialien und Komponenten, die recycelt und wieder verwendet werden können. Dieses Symbol bedeutet, dass elektrische und elektronische Geräte am Ende ihrer Nutzungsdauer vom Hausmüll getrennt entsorgt werden sollen. Bitte entsorgen Sie dieses Gerät bei Ihrer örtlichen kommunalen Sammelstelle oder im Recycling Centre. Helfen Sie uns bitte, die Umwelt zu erhalten, in der wir leben!



EverFocus®